

BOM LIST			
ITEM	PART NAME	Q'ty	NOTES
1	METAL HOOD	2	
2	LONG BOLT	2	
3	NUT	2	
4	SCREW-1	2	M3*12
5	WASHER	2	
6	SCREW-2	2	M3*6
7	SHORT BOLT	2	

REV.	DESCRIPTION	DRAWN	CHECKED	APPROVED
A	NEW RELEASE	ZQJ 11/18/2014	~	ZQJ 11/18/2014
B	ADD P/N CODE	CJ 11/18/2014		

NOTES:

1. PART NUMBER CODE:

LL1055-3A-09 X X X X - X - X

LOGO Support  
 X: W/O LOGO  
 N/A: CONNFTLY LOGO

Shell Plating  
 N: Nickel  
 Z: Zinc

Bolt type  
 L: Long  
 S: Short

Packing type  
 1: Mix packing  
 2: Separation packing

Cover Material  
 M: Metal(Zinc alloy)  
 Positions  
 09: 9pin

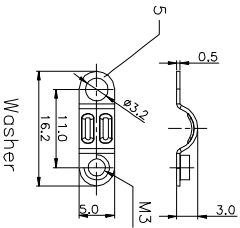
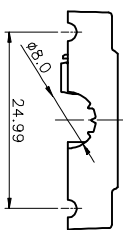
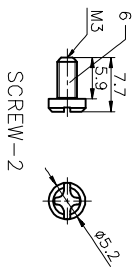
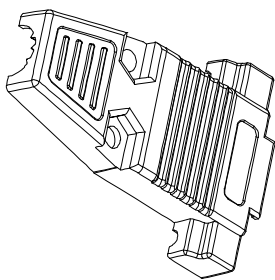
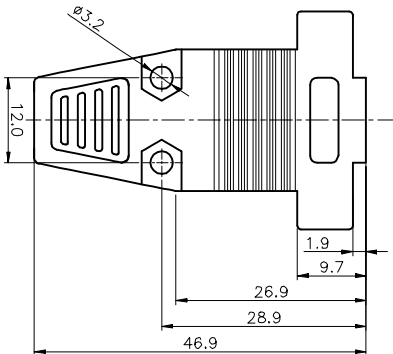
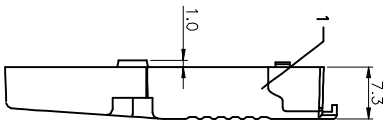
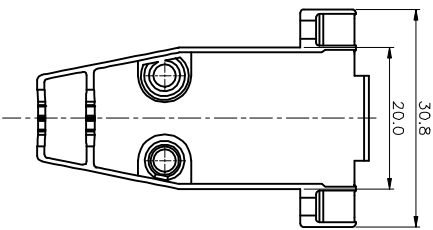

SCREW-1

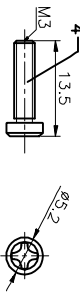

NUT

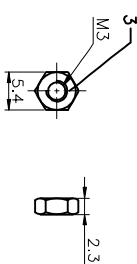

Long BOLT

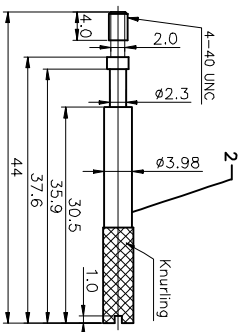

Short BOLT

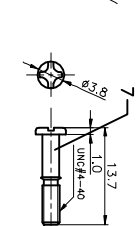

GENERAL TOLERANCE

X: ±0.60  
 .X ±0.38  
 .XX ±0.25

ANGLE TOLERANCE

X: ±5°  
 .X ±3°  
 .XX ±2°

DRAWING TYPE CUSTOMER

SCALE 1:1

DRAWING NO.

PROJECTION

UNITS mm

SHEET SIZE A4

SERIES LL1055-3A

TITLE D-SUB 9pin Metal Hood



慈溪蓝翎电子有限公司  
 CIXI LANLING ELECTRONICS CO., LTD.  
 Tel: 86-574-638510006 Fax: 86-574-638517070